



**Saturday 24th February**

We extend a warm welcome to competitors, sponsors, marketing partners, officials, press & media representatives and the trade to **RALLYE SUNSEEKER 2001** - round 1 of **THE NATIONAL RALLY CHAMPIONSHIP**.

**RALLYE SUNSEEKER 2001** - for the third consecutive year sponsored by Sunseeker Sales (UK) Ltd - leads the way as Britain's most popular rally championship; now joined by competitors in the inaugural Ralliart UK Evolution Challenge as well as contenders from 3 regional championships.

The corporate hospitality stage (run twice) is again to be at Somerley Park, for which we thank our event Patron the Earl of Normanton - why not invite your sponsors to the Gold Club hospitality village?

New for 2001 is our HQ Hotel - the Swallow Highcliff - an excellent 4 star establishment with superior accommodation overlooking the sea. Please patronise this hotel.

The Central Service Area is again at Bournemouth International Airport, all their facilities are available - restaurant/café, bar, shop and toilets - plus a satellite press office and results distribution service, while Scrutiny, Documentation and the Trade Park are at Two Riversmeet Leisure Centre courtesy of Christchurch Council.

Those of you who have competed before will know how popular our sea-front stage is - this will open & close the rally right in the heart of Bournemouth.

Rally FM, the only dedicated radio station to a rally in the UK, will be broadcasting 24 hours a day for eight days. So if you have a sponsor or trade partner, who wants to promote their goods & services, put them in touch with us.

**The maximum number of entries is restricted to just 120, so to ensure you get a run, get your entry in very early!**

Make Bournemouth the place to be at the end of February, **RALLYE SUNSEEKER 2001** will herald in **THE NATIONAL RALLY CHAMPIONSHIP** in style.

## **SUPPLEMENTARY REGULATIONS**

These Supplementary Regulations incorporate the standard Regulations for events in **THE NATIONAL RALLY CHAMPIONSHIP**. Articles and clauses giving information specific to this event are boxed; un-boxed sections are common with other events in the Championship.

### **ARTICLE 1. ANNOUNCEMENT**

Croydon & District Motor Club Ltd and The Southern Car Club Ltd will promote a National A permit Special Stage Rally on Saturday 24th February 2001. The event will be known as **RALLYE SUNSEEKER 2001**.

The event will be a qualifying round of the following championships:

#### **THE NATIONAL RALLY CHAMPIONSHIP**

The ACSMC & ASEMCA Rally 2001 Forest Championship

The 2001 Dunlop ASWMC Loose Surface Rally Championship

The 2001 LCAMC Stage Rally Championship

### **ARTICLE 2. JURISDICTION**

The event will be held under

- (a) The 2001 General Regulations of the Royal Automobile Club Motor Sports Association Limited (MSA) incorporating the provisions of the International Sporting Code of the FIA.
- (b) The ANCRO Championship Regulations of '**THE NATIONAL RALLY CHAMPIONSHIP**'
- (c) The Regulations issued by the various Championships of which this event forms part.
- (d) These Supplementary Regulations.
- (e) Any written instructions the promoting Clubs may issue for the event.

### ARTICLE 3. AUTHORISATION

1. (a) **THE NATIONAL RALLY CHAMPIONSHIP:** TBA
- |     |   |     |
|-----|---|-----|
| (b) | The ACSMC & ASEMC Rally 2001 Forest Championship:       | TBA |
| (c) | The 2001 Dunlop ASWMC Loose Surface Rally Championship: | TBA |
| (d) | The 2001 LCAMC Stage Rally Championship                 | TBA |
2. The event will comply with the Motor Vehicles (Competitions and Trials) Regulations where they are applicable.
3. MSA and DoT Permit numbers will be advised in a Competitors Bulletin.

### ARTICLE 4. ELIGIBILITY

1. **RALLYE SUNSEEKER 2001** is open to Competitors (whether Entrant, Driver or Co-driver) holding valid National A or International Licences issued by the Royal Automobile Club Motor Sports Association Limited, or the Royal Irish Automobile Club or foreign nationals holding a competition licence endorsed 'valid throughout the EU'.
2. Competitors are reminded of the MSA's requirements for Entrants Licences as laid down on the Licence Declaration Form and in the 2001 MSA Year Book.
3. All Competition Licences and Championship Registration Documents will be inspected at Documentation.

### ARTICLE 5. FORMAT

The programme of the meeting will be:

<b>Friday 2th February 2001</b>	- <b>Standard</b> Entries Close @ £450
<b>Friday 9th February 2001</b>	- <b>Late</b> Entries Close @ £550
<b>Monday 12th February 2001</b>	- Competitors Bulletin 1 posted
<b>Monday 19th February 2001</b>	- Road Books etc. posted
<b>Thursday 22nd February 2001</b>	
14.00hrs	Rally HQ at The Swallow Highcliff Hotel, Bournemouth opens
18.00hrs	Rally HQ at The Swallow Highcliff Hotel, Bournemouth closes
<b>Friday 23rd February 2001</b>	
10.00 hrs	Rally HQ opens
11.30 hrs	Sound Test opens at Bournemouth International Airport
12.00 hrs	Scrutineering and Documentation open at Two Riversmeet Leisure Centre, Christchurch
17.30 hrs	Sound Test closes at Bournemouth International Airport
18.00 hrs	Scrutineering and Documentation close at Two Riversmeet Leisure Centre, Christchurch
22.00 hrs	Rally HQ closes
<b>Saturday 24th February 2001</b>	
07.00 hrs	Rally HQ opens - Starters List published
08.15 hrs	Rally Starts, The Square, Bournemouth - 1st Car 'O'
18.00 hrs	Rally Finishes, The Square, Bournemouth - 1st Car 'O' approx.
21.30 hrs	Awards Presentation at The Swallow Highcliff Hotel, Bournemouth/Rally HQ closes.

### ARTICLE 6. CLASSES

1. The class structure will be:
- a) **GROUP 'N'**  
Cars conforming to FIA International Group N Regulations.  
Class N1: Up to and including 1400cc  
Class N2: Over 1400cc, up to and including 1600cc  
Class N3: Over 1600cc, up to and including 2000cc  
Class N4: Over 2000cc
- b) **GROUP 'A'**  
Cars conforming to FIA International Group A Regulations.  
Class A5: Up to and including 1400cc  
Class A6: Over 1400cc, up to and including 1600cc  
Class A7: Over 1600cc, up to and including 2000cc  
Class A8: Over 2000cc

# ADVERTISEMENT

c) CATEGORY 'B'

Cars complying with 2001 MSA Technical Regulations.

Class B9: Up to and including 1400cc

Class B10: Over 1400cc, up to and including 1600cc

Class B11: Over 1600cc, up to and including 2000cc

Class B12: Over 2000cc normally aspirated 2 wheel drive cars

Class B13: Other vehicles over 2000cc; to include Metro 6R4 driven by registered **NATIONAL RALLY CHAMPIONSHIP** contenders with approved sealed engines of 2.5 (International injection) and 2.8 (single plenum type) with an MSA certificate of engine capacity.

The driver of any other vehicle not complying with MSA General Regulation K37.1.1 or 1.2 must, prior to registration, first apply to the National Championship Co-ordinator with full details. Permission to use such a vehicle will then be entirely at the discretion of the MSA to whom details of the vehicle will be sent for ratification. (K37.1.3)

2. a) Vehicles with forced induction will have their engine capacity increased by 70% to establish their class.

b) Should any class have less than five entries, the Organisers reserve the right to amalgamate two or more classes or reduce the awards list as deemed appropriate.

3. **Novice** - A novice shall be defined as any driver who is named as first driver on this event who has never won an overall, class or novice award on any Special Stage Rally as a driver.

4. **Championships** - Where classes in the various Championships differ from those for this event, the relevant Co-ordinator will be responsible for the allocation of points.

## ARTICLE 7. IDENTIFICATION

1. Competitors must make available to the Organisers of the event and the Promoters of the Series, specific areas (2001 MSA General Regulations - Section E) on the vehicle as shown on the diagram below.

- a) The **RALLYE SUNSEEKER 2001** official event logo/title (645 sq cms - MSA GR E2.24.1)
- b) The vehicle competition number to be provided by the Event Organisers
- c) The official **NATIONAL RALLY CHAMPIONSHIP** logo (645 sq cms - MSA GR E2.24.2)
- d) Other advertising proposed by Event Organisers and/or Championship Promoters
- e) Class & Group identification provided by the Championship Promoters

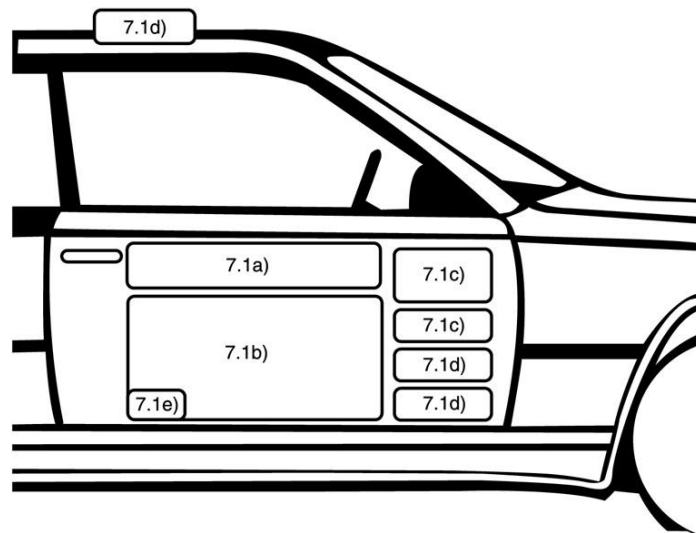

Competitors must display regulation size black numbers, on a white background, on both sides of the car (E11.3.11 & K10.1.2). Competitors are reminded that these numbers must be removed completely after the event or upon retirement from the event.

2. Competitors will also be issued with event rally plates (to be fixed to the front and rear of the car).

3. Competitors may be requested but will not be obliged to carry further advertisements in areas other than those specified in Article 7.1 and 7.2 above.

4. Competitors who do not provide the space required in Article 7.1 and 7.2 above will be either **REFUSED A START** or **EXCLUDED** from the results as appropriate to the case.

## ARTICLE 8. ENTRIES

1. Should the number of entries, overall or in each class, not reach the minimum stated, the Organisers have the right either to cancel the Event or to amalgamate classes where necessary (see Article 6.2 (b) and 8.9).
2. A Competitors Bulletin containing details of the Competitor's start number will be posted to Entrants twelve days before the event.
3. Entrants are required to indicate on their Entry Form their eligibility for the various Awards and Championships.
4. The Order of starting will be at the Organisers' discretion but, to assist seeding, Entrants should note their previous results on the Entry Form.
5. Once the Entry List has been published, no communication will be entered into regarding it.
6. Competitors are advised that information they provide will be stored in a computer retrieval system and may be used for organisation and publicity purposes.
7. Where applicable, the entry fee has been based on the current Forest Enterprise road charges. Should there be any variation in these charges it may be necessary to levy a supplementary entry fee, to be collected at Documentation, although it will be advised to Competitors in advance (E3.1.5).

- 8.a)** The Standard Entry Fee is **£450.00 payable up to and including 2nd February 2001**, inclusive of MSA Insurance & Permit fees (including Insurance Premium Tax, one Service Pack per Competitor and Express mailing of Road Book etc.).
- b)** Management Packs at £40 (which include a Road Book - see Article 21.6) and additional Service Packs at £30 may be purchased by ordering on the Entry Form.
- c)** **It will not be possible to purchase additional Management Packs and/or Service Packs after the final closing date for entries.**
- d)** The Late Entry Fee is **£550**, inclusive of all elements in Article 8a) above, is **for entries received between 3rd & 9th February 2001**.
9. The maximum entry for the Event is 120, plus 30 reserves. The Organisers reserve the right to cancel the event if less than 100 entries are received.
10. All entries must be made on the Official Entry Form, be accompanied by the correct fees and sent to:
- Chrissie Chorley, Entries Secretary**  
**Rallye Sunseeker 2001, The Old Bakery, 55A Belmont Road, Wallington, Surrey SM6 8TE**  
**Tel: 0208-773 3404 (office hours) (24hr Answerphone)**  
**Fax: 0208-773 3704**  
**E-mail: chrissie@xenogamy-plc.demon.co.uk**
11. **Payment may be made by VISA/MASTERCARD see Entry Form for details.**
12. The entry list opens with the publication of these Regulations and will close on **Friday 9th February 2001**.
13. Fees for accepted entries withdrawn up to the Standard Closing date of **Friday 2nd February 2001** will be refunded in full, less **£100.00** administration fee. Those withdrawn after the above date, but up to twelve days before the event, will be refunded less **£150.00** administration fee. Fees for entries withdrawn after that date will not be refunded unless that vacant place is filled by a reserve.
- Withdrawn entries **must be advised in writing** either by post, fax or e-mail to the Entries Secretary.
- Reserve entries that are not accepted will have their entry fees refunded in full, subject to E3.2.6.
14. In the event that the rally is cancelled or postponed, entrants will have their entry fees refunded less **£100.00** administration costs (E3.3.1).

## ARTICLE 9. OFFICIALS

### 1. a) Event

<b>Patron</b>	The Earl of Normanton
<b>MSA Steward</b>	Mr W.S. Troughear
<b>Stewards</b>	Mr John Trevethick
	Mr Les Postlethwaite
<b>Chairman of the Organising Committee</b>	John Lloyd
<b>Stewards Secretary</b>	Sue Winwood

<b>Clerk of the Course &amp; Promotions Director</b>	Rick Smith 020 8773 3404 (w) 020 8773 3704 (fax) e-mail: <a href="mailto:rick@xenogamy-plc.demon.co.uk">rick@xenogamy-plc.demon.co.uk</a>
<b>Deputy Clerk of the Course - Route</b>	Paul Smith 020 8395 1907 (h)
<b>Deputy Clerk of the Course – Administration</b>	Robert Pike 01233 720869 (h)
<b>Deputy Clerk of the Course &amp; Deputy Safety Officer</b>	Mike Summerfield
<b>Asst Clerk of the Course – Ringwood/Somerley Park</b>	Annie Roden
<b>Asst Clerk of the Course - Bournemouth/Avon</b>	Colin Early
<b>Chief Marshal</b>	David Walton 01483 502392 (h) e-mail: davidbravo@aol.com
<b>Chief Safety Officer</b>	Neil Roden 01243 543221 (h)
<b>Asst Safety Officer</b>	Grant Steventon
<b>Clerk of the Works</b>	Neil Boxall
<b>Chief Judge of Fact</b>	Ray Tyler
<b>Secretary of the Meeting &amp; HQ Results Co-ordinator</b>	Lynne Davison 3 Briton Close, Sanderstead, Surrey CR2 0JH 020 8407 1565 (h) 020 8657 4450 (fax) e-mail: lynbriton@aol.com
<b>Entries Secretary</b>	Chrissie Chorley 020 8773 3404 (w) 020 8773 3704 (fax) e-mail: chrissie@xenogamy-plc.demon.co.uk
<b>MSA Eligibility Scrutineer</b>	Mike Harris
<b>Chief Scrutineer</b>	Richard Croucher
<b>MSA Timekeeper</b>	Vaughan Allcock
<b>MSA Environmental Inspector</b>	Dennis Dubber
<b>Results</b>	Tynemouth Computer Services
<b>Equipment Officer</b>	Brian Price
<b>Route Public Relations Officers</b>	Chris & Jan Powis 01732 355676 (h)
<b>Logistics Managers</b>	Chris Morford/Haydn Chappell
<b>Treasurer/Field Results Co-ordinator</b>	Roger Sawyers
<b>Service Area – Chief Official</b>	TBA
<b>Start Area – Chief Official</b>	Gavin Edmiston
<b>Scrutiny – Chief Official</b>	Bill Russell
<b>Spectator – Chief Official - Avon</b>	Steve Howe
<b>Radio Communications</b>	Rally Radio Link
<b>Chief Medical Officer</b>	Dr. Nick Kennedy
<b>Competitors Liaison Officers</b>	Mike Broad
<b>Event Press Officer</b>	Dilys Rogers Andrew Haill 0121 313 1416 (w) 0121 313 1105 (fax) e-mail: andrew.haill@tinyworld.co.uk
<b>Deputy Press Officer</b>	Emma Spearing
<b>Press Office Assistant</b>	Kelly Harris
<b>Rally FM Manager</b>	Paul Sutton
<b>Commentators</b>	Robin Bradford, Graham Robson, Andy Marlors, Toby Moody
<b>Stage Commanders</b>	Jon Cordery, Rob Dance, Matthew Fowle, Barry Guess, Geoff Pickett, Dale Wells
<b>Course Car Drivers</b>	Mick Twiddy, Nick Starkey, Derek Manchester
Telephone calls to officials home numbers - <b>ONLY between 19.00 hrs and 21.00 hrs please.</b>	
b) <b>ACSMC &amp; ASEMC RALLY 2001 FOREST CHAMPIONSHIP</b>	Graham Parry 01705 648 425 (tel/fax)
c) <b>Dunlop ASWMC LOOSE SURFACE RALLY CHAMPIONSHIP</b>	Howard Palmer 01752 342779
d) <b>LCAMC STAGE RALLY CHAMPIONSHIP</b>	TBA

## 2. 2001 NATIONAL RALLY CHAMPIONSHIP

National Rally Championship Co-ordinator	Lyn Jenkins	01792 893323 (h)
National Rally Championship Registrar & Competitor Liaison Officer	Dilys Rogers	01530 222958 (h)
National Rally Championship Press Officer	Roger Gale	0639 635860 (tel/fax)

### ARTICLE 10. RESULTS

1. Provisional results will be published within two hours of the finish of the event. Protests must be made in accordance with O5 and Appeals in accordance with O6. Resumé printed Results will be available at the Rally Headquarters venue after the Awards Ceremony.
2. Competitors shall ensure that they and their cars are available for inspection, should a protest be submitted in accordance with O5.2.2. If the protested vehicle is not available for inspection the Competitor may be penalised as under O3.2.

### ARTICLE 11. ROUTE AND ROAD BOOK

1. The event will contain several Special Stages on private land or on closed public roads, joined by Public Highway sections. Cars will start the event at one-minute intervals. The route will be defined by six figure National Grid references and by a Tulip Road Book.
2. Full details of the Route and Special Stages will be given in the Road Book issued to Competitors. This document will contain all the necessary information to enable Competitors to comply with K3.3.1 and K3.3.2.

An outline of the route giving Grid References for Controls, Stages and Service Areas, stage mileages and time schedule will be sent with a Competitors Bulletin (see Article 5).

3. The Road Book, Map Book & Service Book (and Route Notes if ordered) will be mailed by Royal Mail Special Delivery post approximately 5 days prior to the event to all competitors.
4.
  - a) Ordnance Survey map No 195 1:50,000, latest edition, will be required.
  - b) The route is approximately 173 miles, comprising approximately 16 Special Stages (60% forest tracks, 40% sealed surface roads) which total approximately 73 miles with approximately 100 miles on the public highway.

### ARTICLE 12. SCRUTINEERING AND DOCUMENTATION

1. At Scrutineering cars will be examined for compliance with the 2001 MSA Tyre, Technical and Safety Regulations as well as for class eligibility (attention is drawn to E12, K37 and Q). Each Entrant and driver will be assumed to have full knowledge of the car and it's eligibility for the class entered. Cars must be presented in the same condition as they intend to compete.
2. A validated MSA Rally Special Stage Vehicle Log Book (K25.2/K37.2/E11.3.2) must be made available at Scrutineering, and on demand throughout the event for each car. Failure to produce this document will lead to a **REFUSED START** or **EXCLUSION**.
3. FIA/FISA Homologation Forms valid for 2001 International Rallies must be provided and made available at Scrutineering, and on demand throughout the event, for each Group A or Group N car. Failure to provide the form will either lead to re-classification (where appropriate) to Class B9, B10, B11 or B12 (Article 6.1) or to a **REFUSED START** or **EXCLUSION**.
4. All cars shall have fire extinguishing systems as per 2001 MSA requirements (K37.8.4 and Q3.1.4).
5. Safety Helmets will be examined and must conform to current regulations (Q10) and must be worn on Special Stages (K25.3).
6. Cars shall have fitted and the Driver and Co-driver shall use seat belts (K25.3.1) in conformity with Q2.1.2 and K37.8.3.
7. Drivers and Co-drivers are reminded that they must wear flame-resistant overalls (Q9) on all Special Stage rallies (K25.3.2).
8. All cars must be taxed and insured for the Public Highway (K37.9.1).
9. A valid MOT Test Certificate must be produced at Scrutineering for any car required by law to have such a certificate (K37.9.1). Failure to produce this document will lead to a **REFUSED START**.

10. At the discretion of the Eligibility Scrutineer and the Clerk of the Course certain Competitors' vehicles will be selected for Post Event Scrutiny. Failure to present the vehicle at the nominated place and at the time designated may be considered a breach of O3.2 and may be penalised as under Article 18.7.
11. No studs, chains or non-skid attachments are permitted (K37.5.1).
12. **Tyres:** All tyres must comply with Section R of the 2001 MSA Year Book (K37.5.4).

- 13 a) The Organisers will conduct static Sound Tests prior to the start at Bournemouth International Airport and during the event. These will be conducted in accordance with MSA K5 & E12.17.8, all Competitors vehicles must pass these tests which will allow for a **MAXIMUM OF 100 DB(A) AT 4500RPM USING THE 0.5 METRE TEST**. Failure to do so will result in penalties as under Article 18.4.(a).
- b) Scrutineering and Documentation will take place at the Two Riversmeet Leisure Centre, Christchurch. Cars must be presented at Scrutineering in the same condition as they intend to compete, which includes the display of competition numbers complying with E11.3.11 and other advertising/identification material specified in Articles 7.1, 7.2 & 7.3 which will be provided by the Organisers.
- c) At least 5 days before the event, Competitors will be sent a Time Card specifying their Scheduled Arrival Time at Scrutineering. Failure to comply will be penalised in accordance with Article 18.8.
- d) Competitors must have signed-on and completed all documentation within 1 hour of their Scheduled Arrival Time at Scrutineering, and notwithstanding penalties as under K31(u) if they fail to do so, may be deemed a non-starter and their start number may be allocated to a reserve.
- e) Rally HQ is The Swallow Highcliff Hotel, Bournemouth where the Official Notice Board will be situated for the duration of the event.  
 Rally HQ opening hours will be:
 

Thursday 22nd February 2001	14.00-18.00hrs
Friday 23rd February 2001	10.00-22.00hrs
Saturday 24th February 2001	07.00-21.30hrs

 Rally HQ telephone number is: (01202) 557702

### ARTICLE 13. DAMAGE DECLARATION

1. Competitors will be required to complete and sign a report that they have not been involved in any incident resulting in damage to private property or injury to persons or animals or alternatively giving details of any such incident where damage or injury has occurred (K35.4). Information given will not incur a penalty, but failure to disclose details of any such incident, or failure to hand in a duly completed form will be penalised in accordance with K31(p) and may be reported to the MSA for further disciplinary action.
2. Competitors who do not report at the finish of the event are required to forward the report to the Secretary of the Meeting within 72 hours of the finish of the event (K35.4.1). Competitors who fail to comply may be penalised by a fine of up to £100. If they have been involved in an accident details must be given to the Organisers the same day (see Article 13.1).

### ARTICLE 14. DRIVING STANDARDS/OBSERVERS/JUDGES OF FACT

1. Named Judges of Fact, appointed by the Organisers, will be on duty throughout the rally to observe and report on any Competitor considered to be in contravention of K24.2.11 and K24.2.16. The names of these Officials will be promulgated in an Official Bulletin which will be posted on the Official Notice Board.
2. The Chief Scrutineer and the Eligibility Scrutineer appointed for the event are Judges of Fact in respect of Vehicle Eligibility.
3. The Start Officials on all Special Stages are empowered to judge whether or not a Competitor has made a false start (K24.2.11(c)).
4. The Organisers will appoint Driving Standards Observers in accordance with C13.1 and K24.2.12.
5. a) Any notified offence by a Competitor or by his Service Crew/Management Personnel which involves speeding, reckless driving or failing to observe road signs will automatically be considered as a possible contravention of O1.1.4 (any proceeding or act prejudicial to the interest of the Motor Sports Council or of motor sport generally). The Competitor concerned is liable to be penalised in accordance with K31(k) and/or K31(l), K24.2.14, K34.2 and K34.2.1 and may be called before an MSA Disciplinary Tribunal.

- b)* Any cases reported to the Organisers or the MSA by the Police for speeding, reckless driving or failing to observe road signs will automatically be considered as a possible contravention of Rule O1.1.4 (any proceeding or act prejudicial to the interest of the Motor Sports Council or of motor sport generally) and the competitor concerned will be liable to be called before a Disciplinary Tribunal. It will not be necessary to prove that a traffic offence was committed, as the involvement of the Police may, itself, give rise to contravention of O1.1.4.
- 6. Sound Control:** The Organisers will appoint Judges of Fact and/or Driving Standard Observers, one of who will be the MSA Environmental Inspector, to report on sound levels. Excessive sound will include instantaneous occurrences of noise such as that produced by back-firing caused by anti-lag systems. The penalty for excessive sound may go as far as exclusion.

Competitors should also pay attention to C11 and C12.2.

## **ARTICLE 15. TIMING AND CONTROLS**

- 1.** Timing of the event will be governed by the Target Timing Regulations (K30), using Digital clocks operated by Officials under the control of an MSA Approved Timekeeper.
- 2.** All clocks will be set to Greenwich Mean Time or British Summer Time as appropriate.
- 3.** All Controls will open 15 minutes before the Due Time of Car '0' and close 15 minutes after the Due Time of the last Competitor still running (K29.1), having taken into account any delays.
- 4.** The rally will consist of Special Stages and Road Sections.
- 5.** Lateness in excess of Target Time on Road Sections and Stage Maximum Time on Special Stages is cumulative. The maximum penalty free lateness will be 15 minutes (K30.4e, K30.4f). Once a Competitors' cumulative lateness calculated from the previous Main Control exceeds the maximum penalty-free lateness, the Competitor will be **EXCLUDED** from the results.
- 6.** To be classified as a finisher a crew must report, with their car, at all controls within their permitted maximum lateness (Article 15.5).
- 7.** It is the Competitor's responsibility to ensure that his times are correctly recorded and that Time Cards are handed in when and where instructed. Should any recorded time not be legible or not appear authentic the Organisers may use any means at their disposal to establish a time.
- 8.** Control and Stage Signs will conform with K28.8.
- 9. a)** **Special Stage timing** will be to the previous whole second (K30.2).
  - b)* Each Special Stage will have a Bogey Time set at 65 mph for unsealed surfaces or 75 mph for sealed surfaces, and a Stage Maximum (K30.4c), which will be indicated on the Time Cards.
  - c)* Competitors will receive penalties on Special Stages as follows:-
 

(i) Under Bogey	<b>Bogey Time</b>
(ii) Over Bogey under Stage Maximum	<b>Actual Time Taken</b>
(iii) Over Stage Maximum	<b>Stage Maximum Time</b>

Time in excess of Stage Maximum Time on a Special Stage will count towards the Competitor's Cumulative Lateness (Article 15.5)
  - d)* Competitors must be ready to start a Special Stage when required to do so by the Start Marshal (K25.12).
- 10.a)** **Road timing** will be to the previous whole minute.
  - b)* Each Road Section will be allotted a Target Time based on approximately 28 mph average. Competitors can calculate their Due Time of arrival at any Timing Control by adding this Target Time to their recorded time of departure from the preceding Timing Control. On Road Sections following a Special Stage, extra time may be included to allow for any delay at the Special Stage Finish.
  - c)* At all Timing Controls on Road Sections, Competitors who are early may wait for their Due Time outside the Control area. The time recorded at these controls shall be the time on the official clock when the crew submits the Time Card to the Official, provided that the car and both crew members are within the Control Area. Once a Competitor's car enters the Control Area, the crew must submit their Time Card to the Official within one minute: (i.e. a Competitor's car may enter the Control Area up to 59 seconds before their Due Time, without incurring a penalty for early arrival) See K29.3, K29.3.1 and K29.3.2.
- 11. Timing Controls.** All controls other than Passage Controls (PC's) will be Timing Controls. The following titles shall describe the various types of Timing Control:

**a) Main Control (MC)**

- (i) A Main Control will be situated at the Start and Finish of the Rally, immediately before and after any Rest Halt and at any other specified point.  
At a Main Control after a Rest Halt, competitors will restart at one minute intervals in number order or in the order of their arrival at the Main Control preceding the Rest Halt or in the order of their arrival at some other preceding control or in the order of General Classification at a specified point if interim results are available. The method to be used shall be specified in an Official Instruction.  
Each competitor shall be given a due starting time from any Main Control (OUT), and any difference between this time and his/her actual starting time will be counted towards cumulative lateness and a Time Penalty will be applied.
- (ii) **Regrouping Controls.** The Road Book shall specify the controls, if any, where competitors not excluded by reason of having accumulated more than the maximum permitted lateness at that control, will start the next section with zero lateness towards exclusion.

**b) Special Stage Arrival Control (SSA)**

At this time control the marshal will enter the competitor's time of arrival and the provisional starting time for the special stage which must be a minimum of 3 minutes after the arrival time in order to allow the crew to prepare for the stage. The area between the Special Stage Arrival Control and the Stage Start is Parce Fermé but should the crew need to change a flat tyre a maximum of 5 minutes extra will be allowed without penalty and the start time amended accordingly. Any time in excess of this 8 minutes will be penalised in accordance with K31(d).

**c) Special Stage Start Control (SSS)**

- (i) At the Special Stage Start the marshal will enter the actual start time, which will normally correspond with the provisional start time in hours and minutes, and (if Competitors are to start at 30-second intervals) seconds. Once a Competitor has clocked in at an SSA, the Start Marshal will assume that they are ready to start the Stage and will issue a Start Time as soon as the Start Line is clear, whether the Competitor is ready or not.
- (ii) As each section is timed separately, the time taken from SSA to SSS is 'Dead Time' and delays are automatically allowed for.
- (iii) The area between SSA and SSS is 'Parc Ferme'.

(iv) The start will be signalled by traffic lights which will go from RED (15 seconds to go) through AMBER (5,4,3,2,1 seconds to go) finally to GREEN at the start time. Electronic beams will be used to determine a Jump Start.  
In the event of equipment failure, the start procedure will revert to that described in K25.12 (there will be no 30 second verbal warning for stages starting at 30 second intervals).

**d) Special Stage Finish Control (SSF)**

- (i) A competitor will receive his Special Stage Finish Time in hours, minutes and seconds at the Special Stage Finish Control. This time in hours and minutes will be the start time for the next section.
- (ii) Any Competitor who fails to stop at the Stop line must return to the SSF on foot; reversing the car is prohibited and subject to the Penalty of **EXCLUSION** (K25.9.1 and K31(p)).

**e) Service Control (SV)**

- (i) All Service Areas will have IN and OUT time controls and a Target Time will be specified between these controls and the Section between SV(IN) and SV(OUT) will be marked as a Road Section.

**12. Passage Control (PC)**

- (i) At any point indicated in the Road Book, the Organisers may establish a PC in order to collect Time Cards from Competitors or for other purposes. A Competitor failing to provide the necessary documents at any PC will be deemed not to have reported there and will be **EXCLUDED** (K31(a), Article 15.6 & 15.7).
- (ii) Any times recorded at a PC will be used only to ensure that Competitors have followed the requirements of the Road Book, and not to calculate Cumulative Lateness.

**13.** The MSA has given permission for K26.5(b) to be modified as follows: Competitors will be required to start certain Special Stages at intervals of 30 seconds.

**ARTICLE 16. ROUTE NOTES**

- 1.** Unauthorised pre-event reconnaissance, practising or testing over the Special Stages on this event is forbidden (K6.2 and K26.6).

2. Any Competitor or their agent observed on private land without the relevant permission within the area covered by the maps specified in these Supplementary Regulations after their publication will be **REFUSED A START** or **EXCLUDED FROM THE RESULTS** as appropriate.

The only exception to this regulation will be for persons who live on or whose employment causes them to travel along part of the route used on the event.

3. **Subjective Route Notes.** Competitors may purchase, from the Organisers, comprehensive Subjective Route Notes at a cost of £25, made by an experienced international co-driver, utilising either  
(a) the "number" system (1 = least sharp & 7 = most sharp)  
or (b) the "number" system (7 = least sharp & 1 = most sharp)  
or (c) the descriptive system.

Competitors should indicate on the Entry Form which system of notes they require. Please note once ordered, the type of notes requested cannot be changed and if a competitor neglects to indicate which system is preferred then (a) above will be provided.

Only the Route Note Document provided for the 2001 event by the Organisers may be used (K25.13); - this does not, however, preclude competitors from making notations thereon to suit their own purposes.

In all instances, competitors are advised that the Organisers except no liability or responsibility in the use of the Subjective Route Notes.

## ARTICLE 17. SERVICING

1. Two categories of support vehicle will be permitted; Service Vehicles and Management Vehicles (Article 17.4). Any person travelling in a Service Vehicle is "Service Crew"; any person travelling in a Management Vehicle is "Management Personnel".
2. Each Service or Management Vehicle must be registered with the Organisers, giving its vehicle registration number, before an official Plate is issued for it. The use of a Service or Management plate on a vehicle not previously registered with the Organisers is an offence for which a penalty up to **EXCLUSION** may be applied.
3. There will be Service Areas at strategic points where work may be carried out by the Service Crew and/or Management Personnel on the competing car. These will only be accessible to Competitors and Service or Management Vehicles bearing Official Plates. No other areas may be used by Service Vehicles, which are required to follow a prescribed route to the Service Areas. All other areas will be Out of Bounds to Service Crews and Vehicles.
4. Emergency servicing will be permitted in designated areas after some Special Stages, from Management Vehicles displaying the appropriate Management Plate. These plates may only be used on conventional saloon cars or their estate car derivatives, or on certain 4x4 off-road leisure vehicles, subject to approval by the Organisers. The use of roof racks is not permitted. These vehicles must follow the instructions issued by the Organisers in the Management Vehicle Pack, which will specify sections of the rally route which are Out of Bounds to Management Vehicles. Application for Management Packs must be made on the Official Entry Form (see Article 8.8). The Organisers reserve the right to restrict or refuse any application for additional packs.
5. Competitors may work unassisted on their own cars using equipment carried in the car in 'No Service Areas' except:-
  - (i) within 100 metres of any Control
  - (ii) between the Special Stage Arrival and the Special Stage Start Controls, and
  - (iii) in any Parc Fermé.The only work permitted in these areas is to carry out the following work unassisted:-
  - (a) Replace a wheel with a flat tyre by a wheel and tyre carried in the competing car.
  - (b) Clean lamp glasses, windscreen, windows, identification markings and vehicle registration numbers.
6. Service Crews and Management Personnel are subject to the same regulations as Competitors regarding noise, bad driving manners, etc. Officials and Marshals have been instructed to note any infringement of these rules (Article 14).
7. Competitors are responsible for ensuring that their Service Crews and Management Personnel understand and comply with these regulations and that their Service Vehicle(s) and Management Vehicle(s) bear an Official Plate showing the Competitor's Rally Number. This plate **MUST BE FIXED** to the front of each Service or Management Vehicle and be clearly visible at all times.
8. A Competitor receiving assistance contrary to these SR's will be penalised in accordance with K31(n), subject to the following modifications: any Competitor whose Service or Management Vehicle is *observed* in an Out of Bounds area will be penalised **10 minutes** for a first offence and by **EXCLUSION** from the results for a second offence; any Competitor *receiving assistance* from a Service or Management Vehicle in an Out of Bounds area will be **EXCLUDED** on the first offence.

# ADVERTISEMENT

## ARTICLE 18. PENALTIES

1. Competitors will start with zero time penalties. The results will be established by adding together the times taken during the Special Stages and the time penalties incurred on the road sections together with all other penalties expressed in time. The Competitor with the lowest total will be the winner and so on.
2. If there is a tie, the Competitor who accomplished the best time for the first Special Stage will be proclaimed the winner. If this is not sufficient to be able to decide between the tying Competitors, the times of the second, third, fourth, etc, Special Stages will be taken into consideration.
3. The penalties in K31 apply unless specifically modified in these SR's.
4. a) It is at the discretion of an Environmental Scrutineer, a Judge of Fact, a Driving Standards Observer or the Organisers whether a car which causes excessive sound is **REFUSED A START/REFUSED PERMISSION TO PROCEED/OR EXCLUDED** at any time (K5).  
 b) A Driving Standards Observer's report which results in the imposition of a penalty for excess speed or bringing the sport into disrepute shall also be reported to the Stewards of the Meeting (K31(l)).
5. Competitors are reminded of K24.2.8 for details of computation of penalties in the event that the normal running of a stage be stopped.  
 Should any Special Stage be cancelled during the event, or deleted from the results after the event, only the Stage penalties will be deleted. Unless an Official Bulletin has been issued to the contrary, the cancelled stage must be traversed within the Stage Maximum Time, and will in every other respect be treated as a Road Section.
6. Causing an obstruction on an access road to or from a Special Stage will be penalised by **EXCLUSION** from the results.
7. Failure to attend Post Event Scrutiny within the time limit specified for those Competitors selected, will result in **EXCLUSION** from the results.

8. Failure to report to Scrutineering & Documentation within 15 minutes of the time specified for a Competitor (Article 12.13(c) may be penalised by the Clerk of the Course as under K31(u).

## ARTICLE 19. AWARDS

1.	<b>1st Overall Driver*</b>	The Rallye Sunseeker Trophy and an award.
	<b>1st Overall Navigator*</b>	The Nigel Harris Trophy and an award.
	<b>2nd Overall*</b>	The Bournemouth Trophy and 2 awards.
	<b>3rd Overall*</b>	The Somerley Trophy and 2 awards.
	<b>1st Novice*</b>	The Winter Rally Trophy and 2 awards.
	<b>1st Lady Driver</b>	The 22 Motorsport Trophy and 2 awards
	<b>1st C. &amp; DMC Crew*</b>	The Derek Wickham Trophy and 2 awards.
	<b>1st S.C.C. Crew*</b>	The Challenge Trophy and 2 awards.
	<b>1<sup>st</sup> 'Local' Crew</b>	The Jacksons Mercedes Trophy and 2 awards
	<b>1st in each Class</b>	2 awards
	<b>2nd in each Class (subject to 5 entries)</b>	2 awards
	<b>3rd in each Class (subject to 8 entries)</b>	2 awards
	<b>Highest placed ACSMC/ASEMC†</b>	
	<b>Championship Contender</b>	2 awards
	<b>Highest placed ASWMC†</b>	
	<b>Championship Contender</b>	2 awards
	<b>Highest placed LCAMC†</b>	
	<b>Championship Contender</b>	<b>2 awards</b>

### 2001 NATIONAL RALLY CHAMPIONSHIP AWARDS

#### *To be presented to registered championship contenders only*

1st National Production Cup Driver/Co-driver	2 Awards
1st Formula 2 Driver/Co-driver	2 Awards
1st Junior Driver	An Award
1st Formula 1400 Driver/Co-driver	2 Awards
1st Lady Driver (on index of performance)	An Award
1st, 2nd & 3rd Ralliart UK Evolution Challenge	2 Awards

- \* Both crew members must have been members of the relevant club at the date of issue of these Regulations, a Competitor may only win one of these awards.
- Winners of these Awards will not be presented with Class Awards.
- † A Competitor may only win one of these Awards.

2. Additional awards may be presented at the discretion of the Organisers of the Event.

**ARTICLE 20. INSURANCE**

**ALEXANDER FORBES MOTOR SPORTS CLUB SCHEME (FORMERLY CALLED BRADSTOCKS)**

Competitors must be able to produce their insurance documents at Documentation if required, failure to do so may result in the refusal of a start.

1. All competitors must either -  
Extend their own Private Motor Insurance in accordance with B9.4.2(b).

OR

Comply with the requirements of the Alexander Forbes Motor Sports Club Scheme.

2. **Alexander Forbes Motor Sports Club Scheme**  
The event has applied to Alexander Forbes Motor Sports Club Scheme for a Blanket Cover Note under the above Scheme. This will provide Competitors who need to use the Scheme with the Third Party Cover necessary to meet RTA requirements on the Road Sections of the Event.
3. The basic rate for the Event (before any Loadings) will be £16.95 inclusive of Insurance Premium Tax at the current rate of 5%.
4. To take advantage of the Scheme, each competitor must either:
  - a) Have a valid NES letter in force with no loading applicable  
or
  - b) Comply with the Alexander Forbes Declaration (see 6 below)  
or
  - c) Complete a Alexander Forbes Declaration Form.
5. Competitors who can comply with 4(a) or 4(b) above, simply pay the required premium and sign on the insurance signing on form at Documentation and initial as appropriate. If a competitor can comply with the Alexander Forbes Declaration, they do not have to complete the actual Declaration Form itself.  
  
Competitors who do not comply with 4(a) or 4(b) must complete a Alexander Forbes Declaration Form (available from the Organisers and return it to the Entries Secretary no later than 14 days prior to the event).
6. The Alexander Forbes Declaration  
I declare:  
  
I am over 17 and Held a Full Licence for at least 6 months.  
I have no more than 1 fault accident in last 3 years.  
I have no more than maximum of 6 speeding points on licence.  
I have no physical or mental disabilities  
Have no other material facts to declare

(All Material Facts must be disclosed. Material Facts are those likely to influence the acceptance or assessment of this your risk. Failure to disclose Material Facts may lead to the Insurer declaring the resultant cover to be null and void. If you are in any doubt about facts that may be considered to be material these should be disclosed for your own protection.)

**ARTICLE 21. ADDITIONAL INFORMATION**

- 1 **HOTEL ACCOMMODATION.** Within these Regulations you will find a booking form for The Swallow Highcliff Hotel which is Rally HQ. We have been fortunate in obtaining substantial discounts over normal terms at this hotel and would ask you to utilise this establishment. Please deal direct with the hotel and **NOT** with the Organisers.
2. **MAPS.** Ordnance Survey 1:25,000 and 1:50,000 series maps are available from:  
Maps by Mail on 020 8399 4970
3. **FILMING.** All parties wishing to make film or video recordings of any part of the event for commercial purposes **must** obtain the necessary permission from the Organisers beforehand. Every assistance will be given to *bona fide* applicants.
4. Any competitor wishing to carry an in-car video camera must seek written authority **before 21st February**

2001 from the Clerk of the Course.

5. **MEDIA.** Media packs and passes will be issued only to Media representatives who register with the Event Press Officer prior to the event.
6. **MANAGEMENT PACKS** will include; 1 Management Vehicle Plate, 1 Service Book and 1 Road Book, these must be ordered and paid for before the closing date for entries Friday 2nd February 2001.
7. Some Stages may be run in darkness thus auxiliary lights may be necessary.
8. **INSURANCE.** In the event of a claim having to be made for damage caused to third party property by a competitor, the Organisers and Promoters of the event reserve the right to pass on the insurance excess under the MSA Master Policies (currently £250.00) to the competitor(s) involved.

## **ARTICLE 22. REWARD-A-MARSHAL**

It is moral blackmail time! As many of you are aware, this event runs through highly populated areas - many of the residents are very aware of the rally and therefore come out spectating. This means that we require a lot of marshals (some 700 in 2000!) to stand out on the stages all day to ensure your safety. We like to reward their dedication by giving them lunch and with a large marshals raffle and therefore we need your help! A small donation to the rally fund should ensure that your Documentation will proceed without aggravation! (a figure of £5 is suggested ... we leave it up to you!!)

## **ARTICLE 23. ACKNOWLEDGEMENTS**

ANCRO LTD	FORESTRY COMMISSION	RACETEC
ARB	THE FORGE	RALLY RADIO LINK
BAR MED	F.Y.E.O.	RALLY TIME
BONNER & JENKINS PRINTERS	HAMPSHIRE CONSTABULARY	RALLIART EVOLUTION CHALLENGE
BOURNEMOUTH INTERNATIONAL AIRPORT	HAMPSHIRE COUNTY COUNCIL	RPM
BOURNEMOUTH OFFICE OF TOURISM	HENDY FORD	ST. JOHN AMBULANCE BRIGADE
CHRISTCHURCH BOROUGH COUNCIL	INDOOR KARTING CENTRE	SHERWOOD HOTEL
CMP	IRDC	SHORTWAVE SHOP
COMPETITION CAR INSURANCE	JACKSONS MERCEDES BENZ	SILVERSTONE RALLY SCHOOL
COPYRITE	JIM BAMBER	SLUG & LETTUCE
DESIGNER SIGN COMPANY	LITTEN TREE	SOMERLEY ESTATES
DORSET COUNTY COUNCIL	LEUKAEMIA RESEARCH	<b>SUNSEEKER SALES (UK) LTD</b>
DORSET POLICE	MOTOR SPORTS ASSOCIATION	SWALLOW HIGLCLIFF HOTEL
DTEO	NATS	22 MOTORSPORT
THE EARL OF NORMANTON	OMEGA	TWO RIVERSMEET LEISURE CENTRE
ECLIPSE MOTOR GROUP	THE PARISH COUNCILS	TYNEMOUTH COMPUTER SERVICES
EVENT SIGNS	POOLE CAR CENTRE	XENOGAMY PLC
FINE BITES	PORT VIEW CARAVAN PARK	

Motor Clubs in the South, South East and South West, Radio Crews, Rescue & Recovery Units,  
Rally Doctors & Paramedics.

## 2001 NATIONAL RALLY CHAMPIONSHIP CALENDAR - PROVISIONAL

Date	Event	Contact
24 Feb	Rallye Sunseeker 2001	Lynne Davison, 3 Briton Close Sanderstead, Surrey. CR2 0ZH Tel: 0208 407 1565 Fax: 0208 657 4450
14 Apr	Astra Stages	Andy Kay, 19 Chesnut Grove, Tranmere, Birkenhead Wirral CH42 0LB Tel: 0151 647 5066 Fax: 0151 647 0079
12 May	Steyr-Puch Manx Rally	John Skinner, 6 Berkley Street, Douglas, Isle of Man Tel: 01624 626543 Fax: 01624 661314
2 Jun	Kerridge National Rally	Keith Ashley, 20 Lapwing Close, Kidderminster, Worcestershire DY10 4JG Tel: 01562 68803 Fax: 0121 553 0555
24 June	Ravens Rock Rally	Ann Fitzgerald, The Cross, Moocoin, via Waterford, Eire Tel/Fax: 00 353 51 895238
21 Jul	Port Talbot National Rally	David Williams, Hafren, 7 Penygaer Road Llanelli, Dyfed, SA14 8RU Tel: 01554 772818
8 Sept	The Centurion Rally	Ron Jackson, 13 Kielder Avenue Cramlington, Northumberland NE2 8JT Tel: 01670 734191
20 Oct	Bulldog Rally	John Trevethick, 24 Knights Avenue, Tettenhall, Wolverhampton WV6 9QA Tel 01902 752063 Fax 01902 741418

## ADVERTISEMENT